

AC Sliding gate opener user manual



**Push Button
Input**



**Safety Beam
Ready**



**Smart
Sensitivity**



**Courtesy Light
Output**

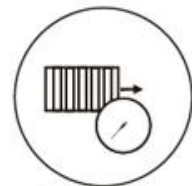

Auto Close

1. Preliminary Checks

To ensure safety and an efficient automation make sure the following requirements are met:

1. The gate structure must be suitable for automation.
2. Make sure that the gate moves properly and uniformly without any irregular friction during their entire travel.
3. The gates wheels and track must be in good condition with no biting, no rust and must be well greased.
4. The gates should be able to be freely opened and closed before installing the gate automation system.
5. It is strongly suggested to have a gate stop installed for the open position for emergency purposes.

Important Safety Information

Installer and owners should observe the following:

1. Make sure that there is sufficient space for the gate to slide open fully without interference.
2. Do not change with parts or components not supplied by the manufacturer, this includes sensors, buttons, and any component not listed in the compatibility list.
4. Make sure all wiring works are correct and in good condition before applying power to the system.
5. Turn off the power when doing any maintenance.
6. Ensure the control panel is not exposed to water to avoid short circuiting of the control panel.
7. Do not supply mains power directly to the motor, control box or any accessories.
8. Do not install the operating system if in doubt. Contact the manufacturer.
9. Do not cross the gate while it is operating, Safety sensors are only to prevent accidents or injuries.
10. Keep the remote controls in safe place and away from children.

Before beginning installation the manual should be read thoroughly concerning all aspects of the installation including all precautions and safety information.

Proper steps should be taken to ensure efficient and safe installation for vehicles, property and persons within the operators working radius.

The system is fitted with an over current sensing feature to assist in preventing damages, injuries and death.

All precautions must be taken by the installer that adjustments are set correct based on the gates weight, height and length.

The system sensitivity should be set to allow consistent operation of the gates under

normal operating conditions.

The system may not detect (Over current sense) against light loads such as small object, young children and animals. It is the operators duty to ensure that the area is clear prior to operation.

Photo sensors or reflective sensors should always be installed to assist in accident or death prevention. You agree to install this product following any and all safety requirements listed in this manual or required under local, state or national regulations. Our company and our distributors, stockist or sellers are not liable for any direct, indirect, incidental, special or consequential damages or loss of profit whether based in contract or any other legal theory during the course of warranty or afterwards. If you do not feel capable of properly installing the operator based on the above information or otherwise do not proceed. Photo evidence of the installation will be required to assist in warranty product claims.

3. Typical Installation Layout

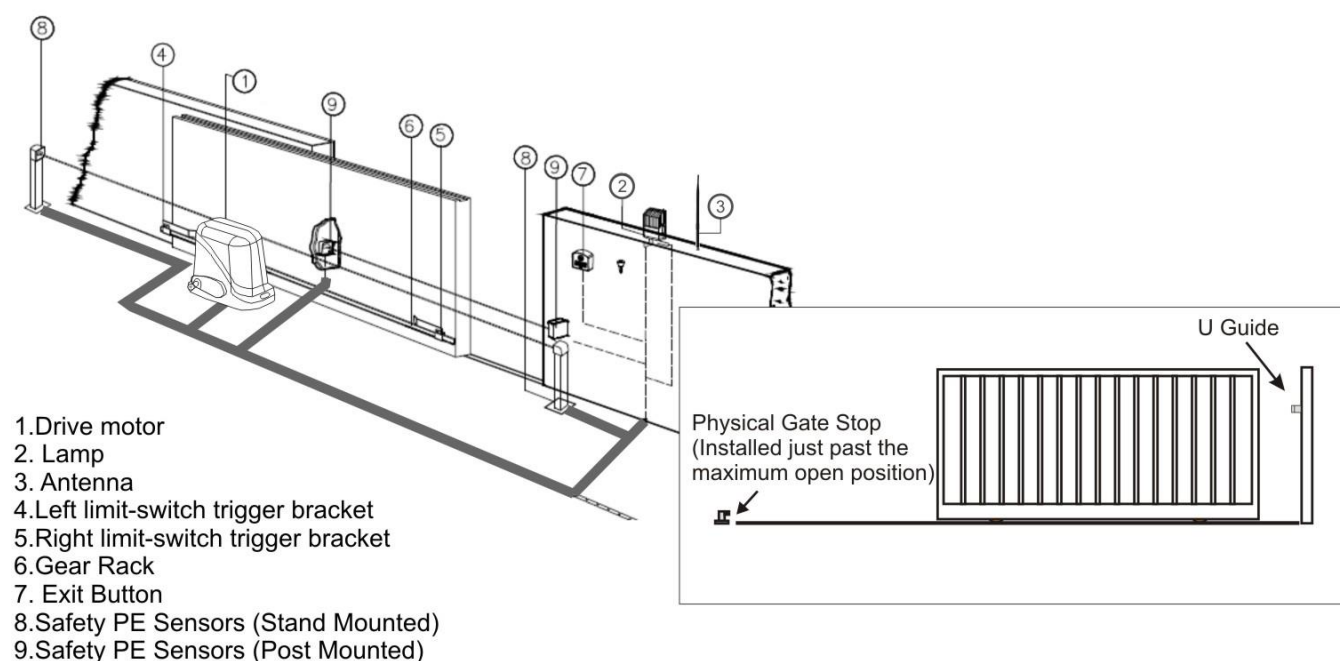

Specifications and Features

1. Working temperature of motor: $-25^{\circ}\text{C} \sim +55^{\circ}\text{C}$
2. Working humidity: $\leq 85\%$
3. Power supply: $110\text{VAC} \pm 10\%$ 50Hz/60H
4. Rated power: 180W
5. Output gear module: $M=4$
6. Output gear number: $Z=16$
7. Output torque: 30.0 N.m

8. Open(close) speed: $v=12\text{m/min}$
9. Rated speed : 1400RPM
10. Maximum pull: 1100N
11. Maximum load: 800KGS
12. Net weight: 11KG
13. Remote control distance : $\leq 50\text{meter}$
14. Packing : In a standard carton
15. Protection Class : B

Features

1. Totally integrated electrical mechanical system
2. Control board interface for photocell's, keypads, press buttons and other access control
3. Safety lamp connection
4. Automatic close

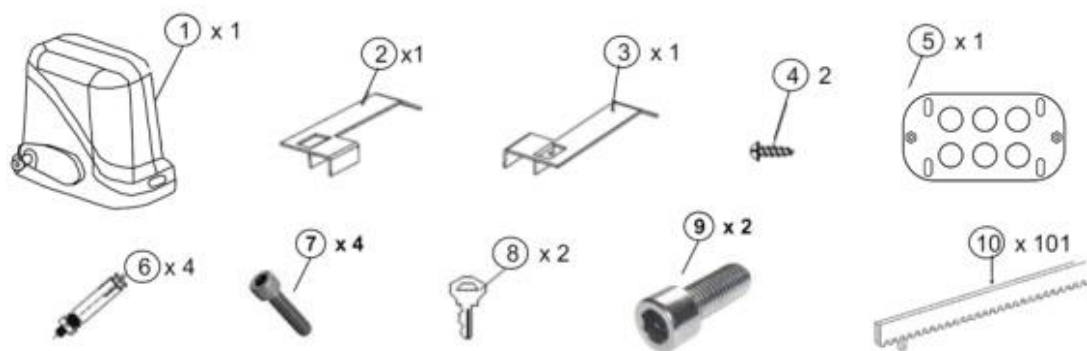

7. Adjustable resistance sensitivity
 - a. Automatically stops and re-opens when an obstacle is encountered (when closing)
 - b. Automatically stops when an obstacle is encountered (when opening)

Standard Kits Contents

Standard Motor Kit Contents

1. Sliding Gate Motor
2. RHS Limit Switch Striker Plate
3. LHS Limit Switch Striker Plate
4. Motor cover screws
5. Motor Base Plate
6. Dyna Bolts
- 7 Striker Plate Fixing Bolts
8. Override keys
9. Motor to mounting plate screws
10. Gear Rack

Dimensions

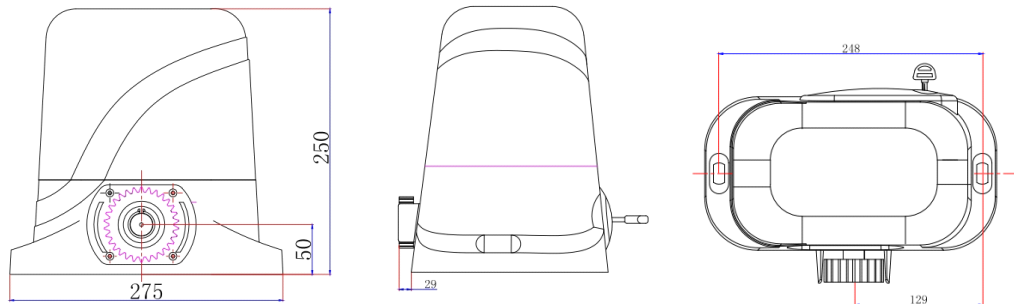

Important Notes

1. Do not operate the gate if there are people or obstacles in the gate's path.
2. The power supply for the control board should be equipped with a separate switch with a fuse rated at 10AMP.
3. Always disconnect the power supply before attempting any service or repairs on the sliding gate.
4. The rack must be fixed securely and in a straight line parallel to the gate track, it must also sit squarely over the drive gear.
5. Ensure the gap between the rack and drive gear is adequate to avoid excessive load on the drive gear.
6. Confirm the direction of the moving gate, the supplied gate stops should be installed in a right position to avoid the motor running out of control.

4. Motor Positioning and fixing

A- Decide on the position that is most suitable to install the motor.

B- Temporarily fit the base plate under the motor housing and place in the position to the gate opener will be fitted, to sure to position the base plate about 35mm away from the gate (see Diagram 1)

NOTE: Place one piece of Gear rack on top of the gear to ensure that you have the right height to install the gear rack

C- Mark around the base plate

D- Remove the motor housing

E- Mark the 4 holes position to be drilled for the base plate (see Diagram 2)

NOTE: Ensure motor base plate is level, if not make the necessary adjustments to rectify.

F- Drill the 4 holes.

G- Fix the motor housing on the base plate

H- Fix the base plate using the appropriate screw (for metal) or dyna bolts (for concrete)

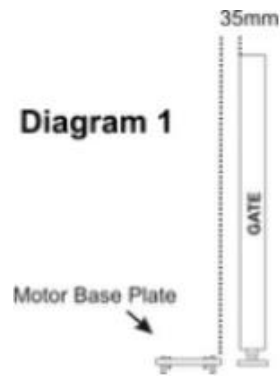
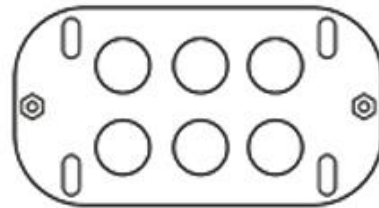

Diagram 2



Preparing and installing the gear racks

Using the supplied key unlock the manual override and pull out the manual override lever (see diagram 3) then manually close the gate.

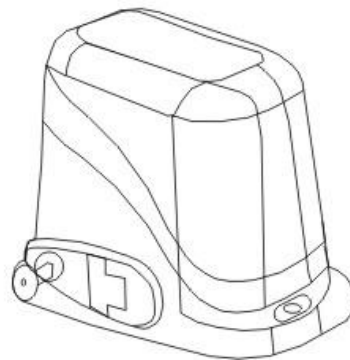

DIAGRAM 3

Insert the key in the key, barrel and turn the key, clockwise and pull to allow the manual override lever to swing out

Install the gear rack onto the gate

Each piece of rack will interlock into the next piece (see diagram 4)

- The best method for installation is to first close the gate using the manual override, sit the first piece on the gear of the motor (make sure it is 100% level first) then fix directly to the gate in the centre of the fixing hole of the rack.

Now loosen the fixing and adjust the spacing between the motor gear and the gear rack (allow 2-3mm gap)

- Re-tighten and fix the next remaining holes on the rack.

Move the gate manually forward and backward along the installed rack to ensure that the gap between the rack and the gear is consistent throughout.

Clip in the next piece of rack into the first (make sure it is 100% level first) then fix directly to the gate in the centre of the fixing hole of the rack.

- Again move the gate manually forward and backward along the installed racks to ensure that the gap between the rack and the gear is consistent throughout. Repeat the above method to complete the racks installation and always be sure to move the gate manually forward and backward every time you install another piece of the rack.

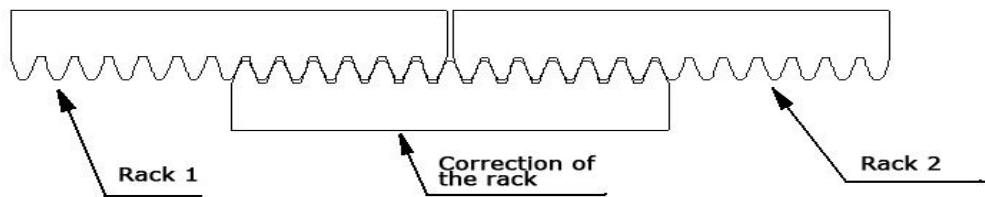
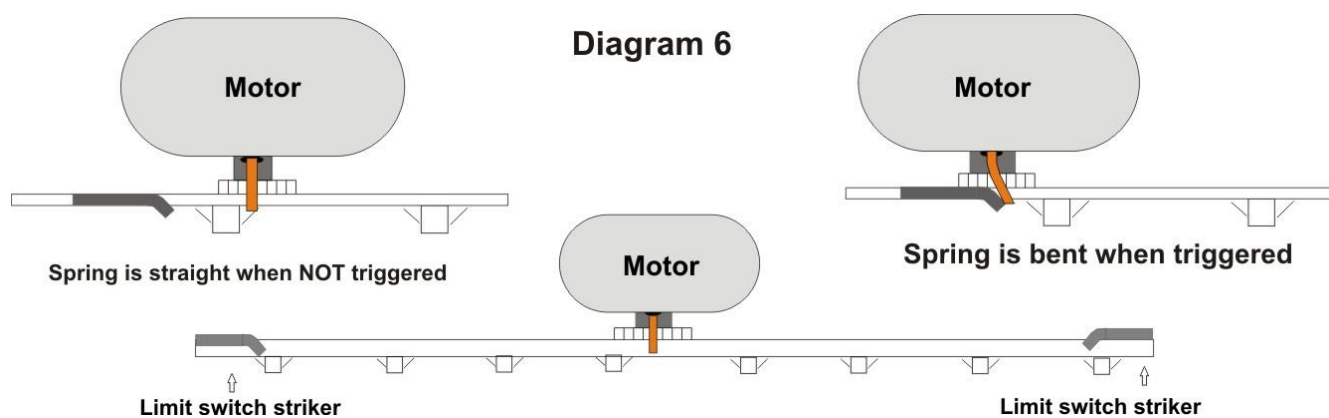

DIAGRAM 4

- The striker plates must be installed now to set the open and close positions for the motors operation. They are fixed onto the gear rack and should strike the limit switch spring on the motor to set the operating parameter (see diagram 6).

- Using the manual override open the gate to the desired open position and install the open striker then close the gate to the desired position and install the closed striker (small adjustment afterwards may be necessary to achieve the best results when the motor is powered later).



5. Power Up and Testing Procedure

- Check the operating direction wiring and switch again
 - Close the gate using the manual override
 - Re lock the manual override
 - Connect the power cord to a 10amp power point
 - Press number 1 on the remote control to start your test
 - The gate should open and stop when the limit switch spring is triggered
- If the gate does not stop when the spring is triggered then reverse the limit switch directions switch

6. Installation diagram of electrical parts (Fig 6)

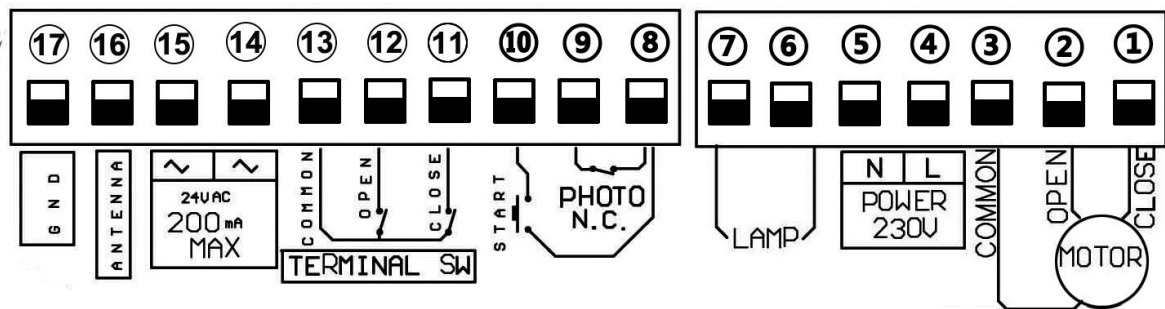

Fig 6

- 6.1. Terminal ④ and ⑤ it for connecting to 220V power
- 6.2. Connect to sliding gate motor
- 6.2.1. Install the motor on the right of gate. (Please see Fig 7)

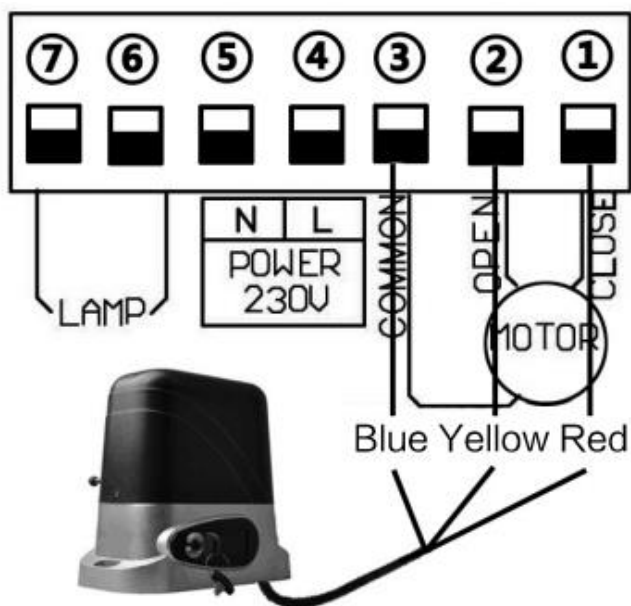

Fig 7

When the motor being installed to the right of gate , motor wires diagram follows

Terminal ① connect the red wire from motor.

Terminal ② connect the yellow wire from motor.

Terminal ③ connect the blue wire from motor.

Please note: Our factory setting is install motor on the right of gate!

6.2.2. Install the motor on the left of gate. (Please see Fig 8)

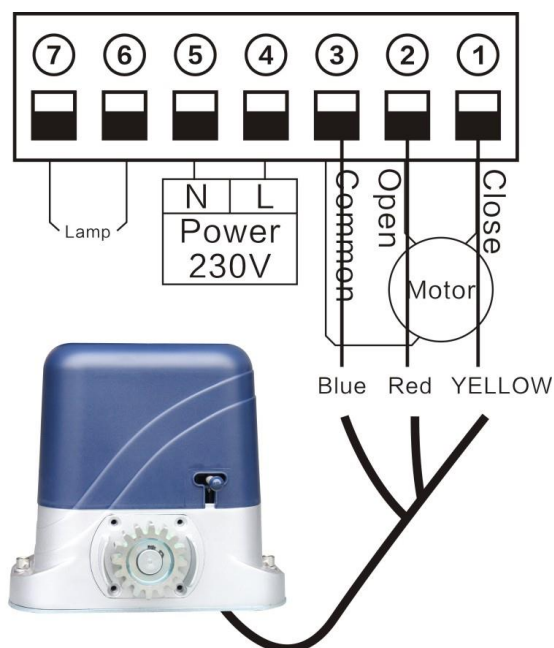

Fig 8

When the motor being installed to the left of gate , motor wires diagram as follows:

Terminal ① connect the yellow wire from motor.

Terminal ② connect the red wire from motor.

Terminal ③ connect the blue wire from motor.

Please note : When you exchange white and blue wire, please check if the motor can close and stop normally. If can't ,please up or down the "K1" to the opposite direction. Note: "K1" includes two pcs short circuit caps, you need to up or down the caps simultaneously, then it work.

6.3.Connect to flashing light. (Please see Fig 9)

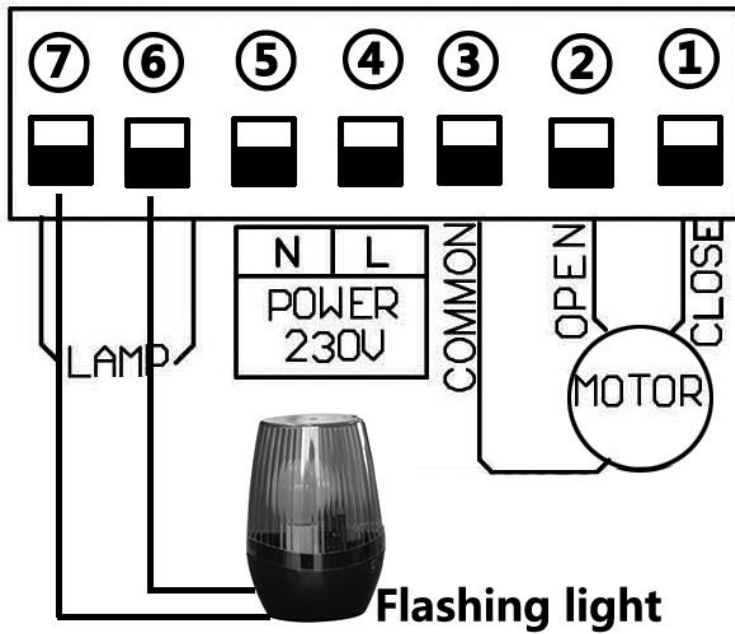

Fig 9

Terminal ⑥ and ⑦ is for flashing light .

6.4. Connect to infrared sensor.(Please see Fig 10)

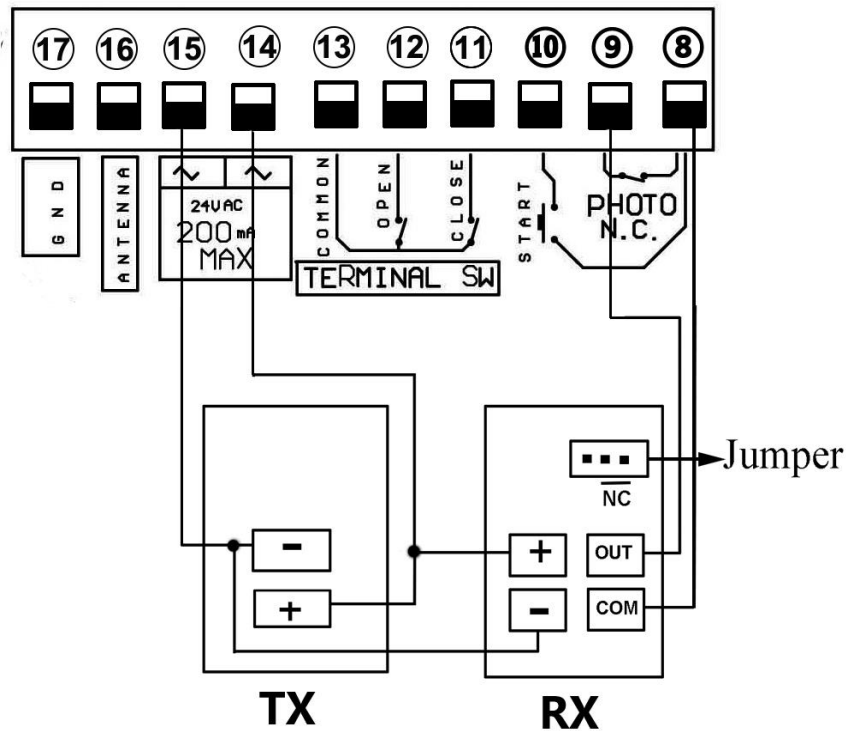

Fig 10

Firstly ,please find a little wire between terminal ⑧ and ⑨,and remove it.

Then, connect terminal ⑧ to the "COM "of photocell RX.

connect terminal ⑨ to the "OUT "of photocell RX.

Terminal ⑭ and ⑮ is supplying power for external device.

So, connect terminal ⑭ to the "+ "of photocell RX and TX.

connect terminal ⑮ to the “-” of photocell RX and TX.

Please note: 220VAC sliding gate control board is designed to connect NC model of photocell, So please keep the jumper on the NC, as picture Fig 10 shows!

6.5. Connect to open device. (Please see Fig 11)

When you don't want to use the remote control to control the gate. Terminal ⑩ is for you connect some external device, such push button, wired keypad, receiver etc.

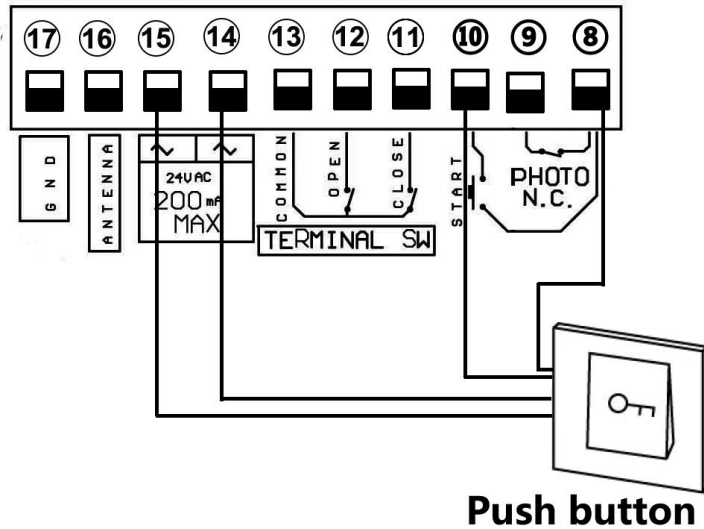

Fig 11

Example for push button;

Terminal ⑧ and ⑩ connect to push button. Terminal **14 and 15** to supply power for push button

7. Function Testing

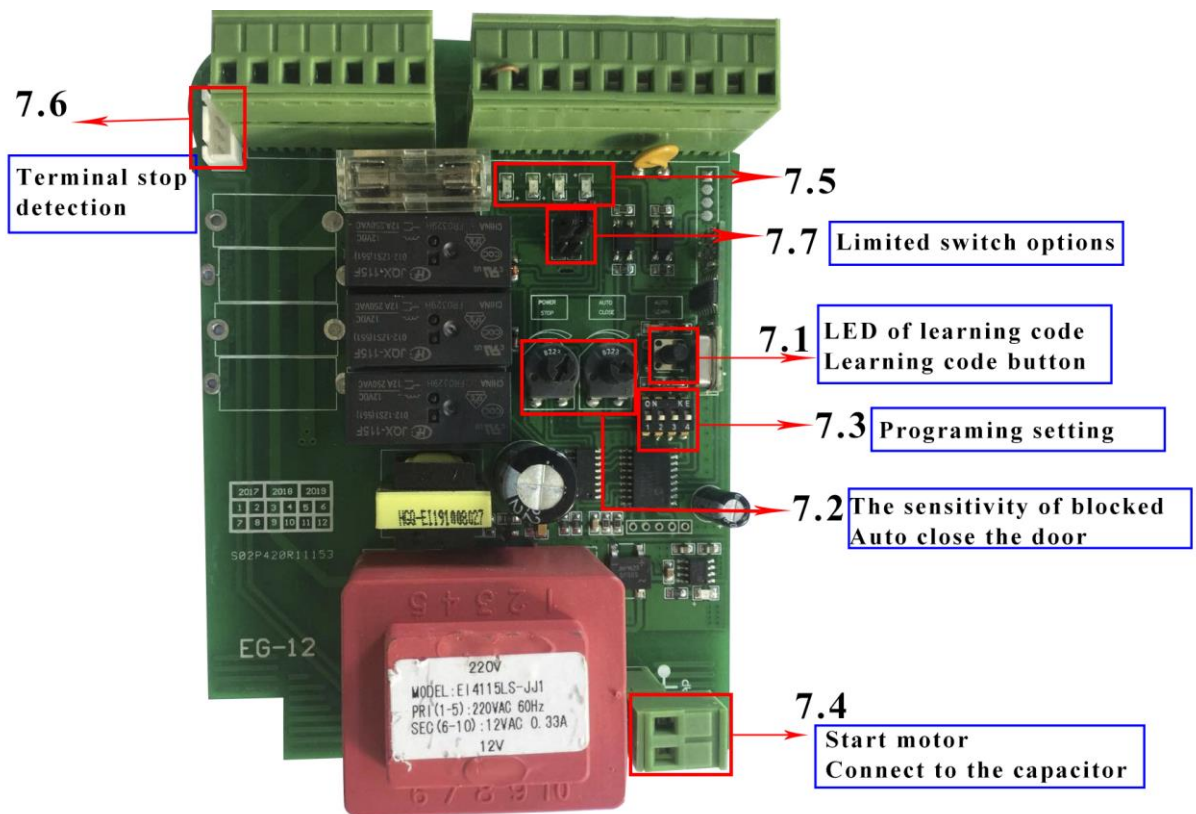

Fig 12

The following functions refer to the picture Fig 12.

7.1 Learn remote control code:

- A. Control panel can memory more than 20 pcs remote control
- B. Press board "AUTO LEARN" button,LED -D5 will lighting for 10 seconds.during this time,we just press the button of remote control.its code will learning and went in.if receiver the code,LED-D5 will go off and motor will start.
- C. If we not press any buttons, LED-D5 will go off after 10 seconds,and receiver will automatic quit learning functions.
- D. Press and hold the button 6 seconds,LED-D5 will flashes ,and then release the button,all the code will be cleared that has been memorized in control board,

7.2 Blocked detection:

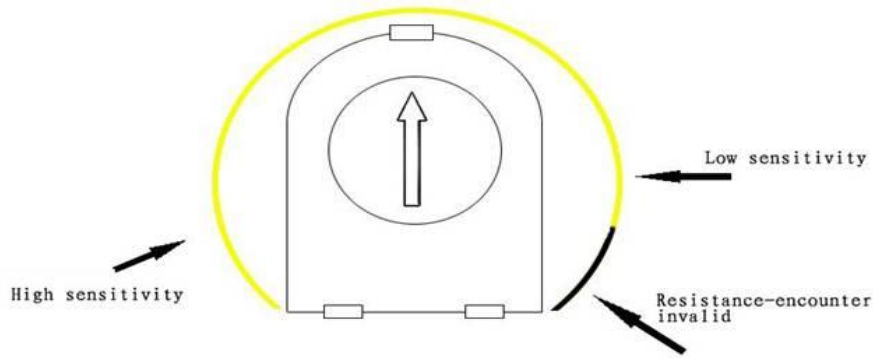

Fig 13

As picture show,we can rotate "POWER STOP "that parts.so we can adjust the sensitivity of blocked.

A. High sensitivity : when the motor is rotation,will meet some minor resistance,then control board will send a signal to let motor stop rotating.

B. Low sensitivity : when the motor is rotation,will meet greater resistance,then control board will send a signal to let motor stop rotating.

Note:when motor is rotation .If LED-D5 flashes,that show system is working now .

C. As picture show, when pointer rotate to black part ,the control panel will quit this system,and when the motor is working ,LED-D5 will not lighting .

7.3 Auto close the door :

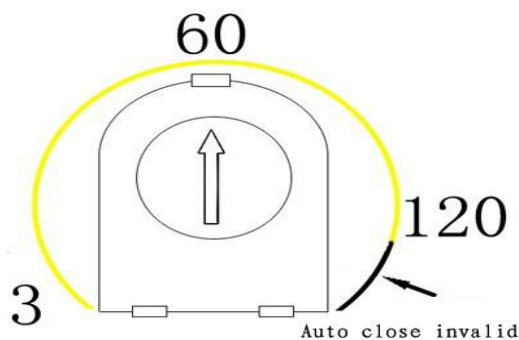

Fig 14

A. When the door is open (as long as there is open),we rotate the pointer to yellow part.the control panel will control the motor to auto close the door,this time can be adjusted in 3 seconds to 120 seconds

B. As picture show,we rotate the pointer to black area.control panel will automatically exits the closed system.

7.4 programming setting:

A. Dial-up 1→off: when motor is working, lamps will always lighting.and motor will stop and after 1 minutes the lamp is off .

Dial-up 1→on: As long as the motor is working, lamp will flashes.the motor is stop and light is off.

B. Dial-up 2→off: Motor control(Including the use of control and short start),motor working as follows
open→stop→close→stop→open……

Dial-up 2→on: Motor control(Including the use of control and short start),motor working as follows
open→stop→close→stop, then automatic open the door ……

C. Dial-up 3→off: when the system is closed state ,there are obstacles to the infrared sensors,the motor will stop it and automatically open the door.

Dial-up 3→on: when the system is closed state ,there are obstacles to the infrared sensors,the motor will stop it.

d. Dial-up 4→off: the resistance encounter is set for high sensitivity.

Dial-up 4→on: the resistance encounter is set for a lower sensitivity.

NOTE: In dial up 4, 'on' position, can let you have more choices for the motor power.

7.5 Motor Start Capacitors:

Capacitors are connected with control board before use motor, please confirmed the interface of capacitors is secure. Please see picture Fig 12..

7.6 Led Indicator:

D1: The infrared sensors output signal instructions

LED ON: Infrared sensors detection, there is no obstacle.

LED OFF: Infrared sensors detection, if there have obstacle when closed the door,the motor will stop working.

D2:

LED ON: We use a conductor make the START this terminal connected with the right of second terminal.the lamp will lighting it. This will realize same function(use the remote control just press one time)

LED OFF: show that no operation.

D3: Limit switch of closing the door

LED ON: The door is not completely closed

LED OFF: The door has been completely closed

D4: Limit switch of opening the door.

LED ON: The door is not completely opened

LED OFF: The door is completely opened

7.7 Terminal stop detection interface:

Terminal stop detection have 2 type, one is open the door, another is close the door. If normal working. 2 pointer will connect to two positions,when in right position, will break it.

Our products has set it and connected it before send to our customers.

7.8 Limited switch options (K1):

Limit switch is used to switch terminal stop detection interface,that direction of open and close the door

Preparation and testing :

Separating clutch, and then use hand push the door, let the door to sliding all journey, and check the door is flexible or not and check racks happen stuck phenomenon of not ? If have,please readjust motor position or racks position. until let the door can move flexible.

After installation of sliding gate opener system,please confirmed the direction of open and close the door push the door to a sliding door machine, is located near the center of the door.then close the clutch.and check electrical lines, to make sure all lines are have connected good.(according to connected electrical diagram 8 to connect it) .Finally, connected the power,and use remote control to control and move the gate,then trigger an infrared sensors.the gate will stop .show that door action is closed.

Or, will delay closing the door,and time will shorter. Use remote control to control and move the door several seconds, then closed .and waiting for door can automatic move.if not.use the remote control to control and move the door several seconds again.and then waiting for door can automatic move.if can automatic move,show this action is closed the door. if closing direction do not tally with the actual direction,that will show that remote control make the motor stop and please disconnect the power. Please change the motor and control panel connection, means change OPEN and CLOSE these 2 lines.

After test direction,please adjust the motor limit switch .Adjust and test limit switch of opening and closing the door.recognize it and let the motor according to actual open and close the door .when motor open and close,we will use hand to toggle limit switch to simulate the door has been opened or closed in position.If door is stop,that show the limit in the right direction.if not stop,that show the limit in the wrong direction. so have to use remote control to control and stop moving.and then toggle limit switch(K1), make the limit in the right direction.

This gate opener has two type of security protection functions: when meet obstacles have anti-collision function. Infrared sensors anti-collision function.

When meet obstacles have anti-collision function: when gate opener is in the process of opening or closing the door.when the door meet resistance, the motor will stop rotating.

Infrared sensors anti-collision function. when the door is in the closed state,if a person or a car ,just in and out of the door ,the door will stop sliding,and will rebound.

Automatic closing the door: after opening the door,without use remote control to control ,after several time later,the door will automatically closed.

8. Maintenance

1. The rack and drive gear should be kept clean. Do not attach any objects to the gate that may interfere with the rack or drive gear.
2. Should frequent clean the sundries on the magnet limit.
3. Lubricate all moving parts every 3 months.
4. If the control circuit board is fitted with an optional back up battery, check the condition once a month and replace if necessary.
5. Check power cables and conduit have not been damaged.
6. During heavy rainfall or light flooding ensure the motor housing has had no ingress of water.

9. Trouble Shooting

Problem	Possible causes	Repair method
Gate fails to operate	<ol style="list-style-type: none"> 1. Check the clutch states ,power-driven state or not ? 2. Power no indication,and power trip. 3. The fuse has broken 4. Remote control failure or invalid 5. Damaged power cable 6. Remote control or motor problem 	Recovery To restore power Change the fuse Detection or change Detection and Repair Detection and Repair
Working distance of remote control reduced	<ol style="list-style-type: none"> 1. Low battery power or damaged 2. Interference from equipment using the same frequency 3. The receiver of controller was damaged 	Replace battery Wait eliminate interference Replace the control board
Gate fails to stop at start or end position	<ol style="list-style-type: none"> 1.The terminal stop toggle switch is damaged or obstructed. 2. Limit switch of the motor and the limit detection of the interface PCB board plug off. 3. Limit of open and close is in wrong position. 	Replace toggle switch or remove obstruction Insert and fixed it Adjust of limit switch(K1)
Press open and close key of motor, but cant working and operate	<ol style="list-style-type: none"> 1. Blocked sensitivity is too high(set too big) 2. The gate has lifted off the track and disengaged the drive gear from the rack 	Make blocked sensitivity lowered ,and check gear and racks can operate normally. Maintenance and replace.

10. Important Notes

1. When someone or obstructions between the door, do not open or close the door,

to ensure safety.

2. The power supply for the control board should be equipped with a separate switch with a fuse rated at 10AMP.

3. The control section has a strong power, cut off the power before opening the motor cover.

4. Motor gear modulus $M = 4$, number of teeth = 16, use the corresponding racks

5. The door should be done straight, after making sure racks fixed good, and the door

can be in a good position with motor gear.

6. Racks and gear should be controlled in good gap, so can make sliding steady.

7. Confirm the direction of the gate movement, and magnet limit should be fixed in good position, to avoid failure causes the motor to run out of control.