

EN ISO 9001:2008
TUV NORD

WRAS
APPROVED PRODUCT

EN
1388 - 2
Manufactured According to

EN
12976
Manufactured According to

CE
400380
EU CONFORMITY VERIFICATION NUMBER

VITREOUS ENAMEL
DIN 47533
www.enamels.com



SOLAR WATER HEATER WARRANTY

- > SAFETY INSTALLATION CONDITIONS
 - > SAFETY RECOMMENDATIONS FOR THE INSTALLATION AND MAINTENANCE OF THE SOLAR WATER HEATER TANK
-



Read carefully the safety installation manual, maintenance and warranty terms before installing the device, so as to avoid possible damage and to protect yourself from any risks.

CONTENTS

SOLAR WATER HEATER WARRANTY

THE COMPANY OFFERS THE FOLLOWING WARRANTY	3
WARRANTY TERMS	3
THE WARRANTY DOES NOT COVER.....	4

SAFE INSTALLATION CONDITIONS

GENERAL INSTRUCTIONS.....	4
INSTALLATION LOCATION	5
SPACE REQUIREMENTS FOR THE INSTALLATION.....	5
ORIENTATION - BEST INCLINATION - SHADE	5
INSTALLATION PARTICULARITIES.....	5
SPECIAL WEATHER CONDITIONS.....	5
WORKING CONDITIONS.....	6
PERSONNEL REQUIREMENTS	6
DEVICE TRANSPORTATION	6

SOLAR WATER TANK CONNECTION AND MAINTENANCE SAFETY ADVICES

HYDRAULIC CONNECTION OF THE SOLAR WATER HEATER TO THE COLD AND HOT WATER NETWORK	7
ELECTRICAL HEATING UNIT	8
PARTS AND COMPONENTS OF THE ELECTRICAL HEATING UNIT-THERMOSTAT	8
CONNECTION OF THE ELECTRICAL HEATING UNIT TO THE THERMOSTAT	9
CLOSED CIRCUIT FILLING	9
RECOMMENDED SYSTEM INSPECTIONS	10
SYSTEM CHECK UPS.....	10
MAINTENANCE BOOK.....	11

TEXT MARK EXPLANATIONS:



SAFETY TIPS



LEGAL NOTE



IMPORTANT INFORMATION

SOLAR WATER HEATER WARRANTY

THE COMPANY OFFERS THE FOLLOWING WARRANTY:

- > For the solar collector ten (10) years warranty.
- > For the heat tank five (5) years warranty.
- > For the electric resistance of the thermal tank two (2) years warranty.

FURTHERMORE, THE WARRANTY IS VALID ONLY WHEN THE FOLLOWING TERMS ARE SATISFIED:

1. The solar thermal system must be installed and maintained by specified and certified personnel.
2. The magnesium bar of the heat tank, must necessarily be checked every year and it must be replaced instantly if it has been outworn to a percentage above 50% or it has been covered by the accumulation of salts.
3. The standard of the water quality used by the system should not be lower than the potable (page 4 table)
4. The closed circuit fluid should be specially designed for solar thermal system, should be non-toxic, corrosion-resistant and resistant at the specified temperatures.
5. The tank as well as the solar panel should be grounded.
6. The water supply pressure should not exceed 8 bars, otherwise a pressure reducer should be installed.
7. System temperature and pressure should not exceed the specifications as indicated in the device's technical manual.
8. The tank should always have safety valves that will protect the system from the maximum temperature and maximum operating pressure. For the proper operation of the heat tank and solar collector and to avoid damages, it is necessary to check the safety valves and in case of malfunction must be replaced .
9. The area where the system is to be installed must have a functional water drainage on the floor.
10. The user must take all appropriate measures to exclude the overheating phenomenon.
11. The hydraulic connections to the tank must be such as to exclude the phenomenon of electrolysis.
12. The tank should not be damaged by a drop or a hit during transport or installation.
13. Maintenance of the solar water heater must be in accordance with the maintenance schedule which the installer has design.
14. The installer and maintainer should record the tasks and the reason why they were called in the maintenance book. This record file is a key element of the warranty and should be made available on request.
15. All repairs or maintenance must be carried out using quality spare parts which are specific indicated in the device's maintenance book.
16. The installation must meet the conditions described in the installation manual which is an integral part of the warranty.
17. The temperature in the closed circuit should not exceed the maximum endurance temperature specified in the closed circuit fluid specifications.
18. The electrical resistant is not part of the system but an additional heating element and it should be installed by specified and certified electrician. The electrical resistant is used only in case the temperature of the water into the heat tank is under 50°C. In any other case, the electrical resistant should not be used. The constant and unreasonable use of the resistant may cause damage to the tank and is out of the warranty.

ATTENTION!



Very poor water quality at the water outlet can result in salt formation and salts may block the safety valve. In this case, the tank remains unprotected against very high temperatures above 90°C and high pressure (greater than 10 bars). For example, if the safety valve is blocked by salt and the tank reaches a pressure of 16 bars, there will be a leak in the flange, there is a high probability that the enamel coating on the perimeter of the flange will be destroyed and the force exerted on the flange will be about 1 ton.



For this reason and to avoid the overheating, accurate measurement of the solar panel's surface is suggested, especially in areas with high solar radiation. Extremely big collective area or collectors with lower limit of liquid capacity, which are not in accordance to the

safety function specifications of the solar tank may cause damage and place the tank out of warranty.

THE WARRANTY DOES NOT COVER:

- Breaking the glass panel, the solar collector.
- The magnesium rod in the tank.
- Damage to electrical parts of the tank due to excessive salt concentration.
- Damage to safety valves of the tank, by excessive concentration of salts or external bodies.
- Tank or solar collector damage due to excessive pressure of the water supply network.
- Tank or solar collector damage in cases of water heater systems, in which flows water directly from the water supply system to the solar collector tubes (open circuit).
- Damage of the tank caused by overheating.
- Damage caused by unauthorised third party intervention.
- Damage caused by improper maintenance.
- Damage caused by extreme operating conditions and extrinsic factors (*vandalism, fire, extreme weather conditions, etc.*).

NOTE: *In the event of a breakdown, the workshop's fees and transport costs are borne by the customer in any case. The manufacturer reserves the right to change the terms without notice.*

WATER SPECIFICATIONS TABLE

ELEMENT	PRICES
pH	7-9
Total hardness	< 100 mg/l
Chlorides	< 0,5 mg/l
Free chlorine	< 80 mg/l
Conductance	< 650 mS/cm 25°C

SAFE INSTALLATION CONDITIONS

This is an integral part of the warranty to which it refers. It is not an installation guide. It refers to the appropriate conditions for a safe and right installation.

GENERAL INSTRUCTIONS

1. This manual is an essential and indispensable part of this device. It has to be carefully kept and always accompany the device.
2. Please read the instructions and warnings carefully. They contain crucial information concerning the safe installation, operation and maintenance of this new device.
3. The responsibility of installation lies with the buyer and has to be performed by an authorized specialist.
4. Using the device for reasons other than those specified in the manual is strictly prohibited. The manufacturer shall not be held liable for any damage caused by improper or unjustifiable use or by failure to comply with the instructions in the manual.
5. Installation, maintenance, and other special work on the device have to be performed by a specialist, always in compliance with existing instructions provided by the manufacturer.
6. Faulty installation may cause personal injury or damage your property. The manufacturer shall not be held liable for such damage.
7. Keep all packaging materials (*clips, plastic bags, polystyrene foam*) out of reach of children, as hazards may occur.
8. All repairs must be performed exclusively by an authorized specialist, using only the appropriate parts. Failing to comply with the instructions above may affect your safety and relieves the manufacturer of all responsibility.

CAUTION!



The installation must comply with local regulations, concerning hydraulic and electrical installations. Removing the packaging must be done on site, in order to protect the device from being damaged during transportation, all the while taking care that the collectors do not lean against the pipe connection jacks. You also have to remove the plastic protection plugs from the tank and collector connection jacks. Filling the solar water heater must not take place under the sun, so as to avoid the collectors getting overheated. In order to achieve this, the collectors' glass-panels have to be covered at all times during installation (until the system is filled up). The tank of the solar water heater (usage water) should always be filled first and then the collector's circuit. (Water and anti-freeze solution).

INSTALLATION LOCATION

Before installing the solar water heater, you have to choose the right location carefully and check the surface, to ensure it can bear the device's weight. The installation location must not be overshadowed by trees, buildings or other objects all year round in order to ensure the selective surface's unhindered exposure to solar radiation. The solar water heater must be installed on a flat surface with adequate bearing capacity. Before moving forward with installing the device, make sure that the rooftop/ roof and the whole construction has adequate bearing capacity when it comes to static, according to the maximum weight on the installation location. If the chosen location is situated in an area with a high wind and snow activity, the whole system has to be statically checked by an authorized specialist (*special engineer*). In special occasions, additional support or a more durable construction may be needed. The installer is responsible for the assembling, installation and the stability of the system.

SPACE REQUIREMENTS FOR THE INSTALLATION

CAUTION!



There has to be a minimum safety distance of 2 meters perimetrical of the installation so that:

- The collectors are accessible for maintenance.
- The collectors and the supporting system are not exposed to strong winds that may occur around the corners and the edges of the rooftop.
- Snow can be easily removed.

CAUTION!



The installer with the consent of the owner should take all the precautions and every necessary action in order to ensure that the installation area is safe so that, in case the system falls, no lives or properties would be threatened.

ORIENTATION-BEST INCLINATION-SHADE

The right choice of inclination and the orientation in combination with the location and the time of the year during which we need maximum efficiency make up an important factor for the optimum efficiency of the solar water heater. The solar water heater has to be orientated in such a way, so that the selective surface faces towards the South, when it comes to the northern hemisphere (*and towards the North, when it comes to the southern hemisphere*). Deviating from the above orientation may lead to decreased efficiency. If such a deviation cannot be avoided, then the system's efficiency has to be complemented by increasing the selective surface, following a study and evaluation of those specific conditions. Because the solar radiation incident angle is changing throughout the year and its also depends from the installation location, the inclination angle of the collectors has to be proportionate per usage.

INSTALLATION PARTICULARITIES

In case the chosen surface is not compatible with the standard equipment provided, another kind of equipment will have to be used. Responsibility for choosing the equipment lies solely on the installation expert and not on the manufacturer. It is up to the installation expert, whether they will suggest using another kind of equipment to the customer, to which the customer has to have agreed upon prior to the installation.

CAUTION!



Solar system has to be Installed and operate on the same day. If for any reasons makes such fact impossible, you should follow the procedures below:

- You should not connect the collectors with the tank (closed circuit)
- You should not connect the tank with the supplies in-out (open circuit).
- Collectors should be completely covered (black out) during the period which shall not be functional

- Collectors caps (plastic) should not be removed before the collector be connected with the tank, in order to avoid dust or other materials enter in the circuits (open-closed)
- Do not connect the electric element (if existing on the device)
- For the period solar system shall be installed but won't be functional, especially in areas with immense solar radiation and high temperatures, is recommended to periodically check the caps conditions (of the collectors & the tank) and the collector covers, for verify eventual damages and their replacement if it's required
- Before make operative the solar system is suggested to clean the tank (open-close circuit) and the pipes of the collectors.

SPECIAL WEATHER CONDITIONS

In areas that suffer from heavy snow, make sure that you remove the accumulated snow as soon as possible. In that e case and also in the case of strong winds, rains, strong winds, cyclones and hurricanes, the system has to be installed on the rooftop as securely as possible, and tied down with additional metal strips. In areas with the above weather conditions and with more than 20mm hail, the solar water heater has to be insured.

WORKING CONDITIONS

Keep the installation area clean and free of objects that may hinder the installation process. Do not allow other people, apart from the installation expert, to get near the tools, as well as the installation location. Use only parts that are compatible with the water heater you bought. The use of other parts or unsuitable tools may cause accidents or pose other hazards.

PERSONNEL REQUIREMENTS

The installation of solar water heaters has to be performed exclusively by authorized installation

experts (*technicians*). Always wear protective glasses, suitable working attire, protective shoes and helmet. In hazardous locations, such as leaning rooftops or great heights, all protection measures must be taken and only special equipment must be used.

DEVICE TRANSPORTATION:

Collector transportation and handling

- All abrupt vertical movements during the transportation of the collector must be avoided.
- Take special care of handling the glass side while transporting the collector. Do not transport or place the collector with the glass side face down.
- In order to avoid possible damage, do not remove the packaging, until it reaches the final installation location.
- Do not place the collector on hard or uneven surfaces.
- Cover the collector's glass until you the solar water heater starts operating.

Condensation

During the early hours of the morning and late in the afternoon the inner part of the glass may steam up or condensation may form on the outer surface. The higher the humidity of the air, the larger the amount of condensation that may form. In case condensation forms, it will gradually go away, as the collector gets exposed to the sun. This is a temporary phenomenon and is depending from the air humidity of each region.

Transportation and handling of the tank

Abrupt movements must be avoided during the transportation of the tank, as they may result in fall and damage.

- You must be extremely careful while lifting the tank and always take precautions, in order to avoid possible accidents, injuries and other hazards.
- To avoid damaging the tank, do not remove the packaging, until it reaches the installation location.
- Do not place the tank on hard or uneven surfaces.

RECOMMENDATION



During the system's use there might be gathered precipitates, other materials and Biofilm in the tank. This is mainly due to the bad water quality, to the water supply network, to the water pipes and to the water heating exchanger inside the tank. The for mentioned phenomenon might deteriorate the water quality so it is recommended apart from the scheduled tank cleaning also a filter placement to the water inlet from the water network.

SOLAR WATER TANK CONNECTION AND MAINTENANCE SAFETY ADVICES

Necessary system cleaning before connection and first operation. Before filling the solar system with water, you must first completely wash out the closed circuit of the tank and the same is suggested for the pipes of the collectors. Is recommended also the washing of the open circuit before the use. Aggregates can affect negatively the efficiency of the system.

1. HYDRAULIC CONNECTION OF THE SOLAR WATER HEATER TO THE COLD AND HOT WATER NETWORK

On the tank you will find the connection jacks along with a description for their individual use.

CAUTION!



Cold and hot water network connection must be performed using only adaptors. Any Weldings are prohibited.

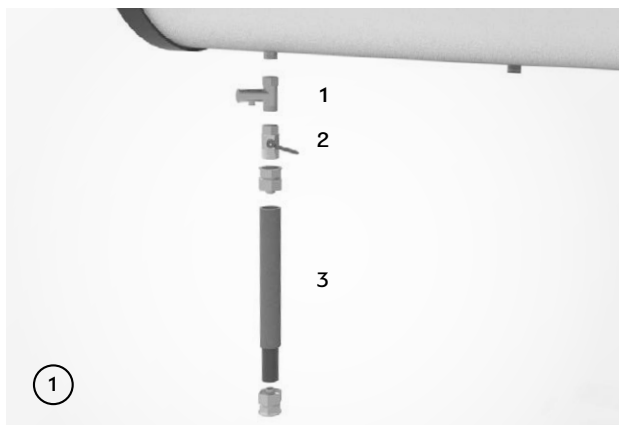

1. To the inflow with the inscription "NETWORK WATER", firstly connect the safety valve (10 bar) [1] and then the switch (valve) [2]. Then connect the cold water inflow to the switch with an insulated plastic pipe [3].



2. Connect the inflow with the inscription "HOT USAGE WATER" to the hot water inflow jack of the

consumption network with the aid of an insulated plastic pipe. (It is suggested to use a plastic pipe in order to minimise electrolysis phenomenon).

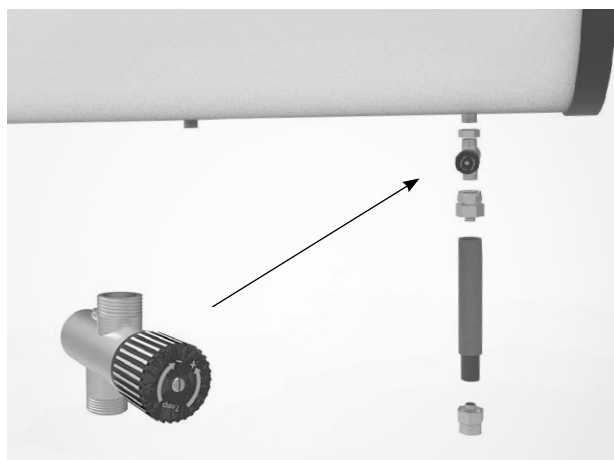

CAUTION!



In order to avoid the risk of burns, connect a thermostatic valve to the hot water outflow.

3. Switch on the valve and fill the boiler with water. Keep the switch and a hot water tap, in house, running (when water comes out of the tap, then the boiler is full and you may switch off the hot water tap and the valve).



4. Finally, in order to avoid overheating and overpressure, a temperature / pressure valve must be installed on the special socket of the boiler on the top of the tank.



CAUTION!



The safety valve has to be equipped with a drainage pipe that will in turn be connected to its exit. This pipe must be located above the surface of the floor and near a run-off canal, in order to avoid flooding in case of a leakage. Do not seal or block the edges of this pipe or the exit of the valve. Follow the instructions for the installation and maintenance of the valve that are included in the packaging.

ATTENTION!



Only wrench, should be used during installation of the pipe joints fittings . Tools like pipe wrench is prohibited because the can cause seriously damage due over-tightening. The clamping must be done up to a maximum the thread terminates. For the sealing must be used PTFE tape and sealing thread glue.

2. ELECTRICAL HEATING UNIT

CAUTION!



The electrical resistant is not part of the system but an additional heating element. The installation of the heating unit must be performed by an authorized electrician. The solar tank is delivered with an electrical heating unit upon customer's request.

The heating unit can only be used, if the country's and the installation location's existing legislation allows it. It is situated to the flange of the tank along with the safety thermostat, which is regulated from the manufacturer at 60°C. The magnesium bar is placed at the same flange (with or without the heating unit).

ATTENTION!



1. The devices comply with the regulations EN 60335-1 and EN 60335-2-21.
2. All electrical connections must be performed by authorized electricians.
3. Always connect the earthing wire to the ground or to the base, even if the heating unit is not connected.
4. Do not set the thermostat's temperature above 70°C.
5. Never turn on the electric heating unit when the tank is empty, as that will cause extensive damage. In this case, the manufacturer's warranty is voided.
6. In case the supply wire is damaged, it has to be replaced either by the manufacturer or the service company or by similar specialists, in order to avoid further damage or injury.

CAUTION!



The electrical resistant is used only in case the temperature of the water into the heat tank is under 50°C. In any other case, the electrical resistant should not be used. The constant and unreasonable use of the resistant may cause damage to the tank and is out of the warranty.

PARTS AND COMPONENTS OF THE ELECTRICAL HEATING UNIT-THERMOSTAT

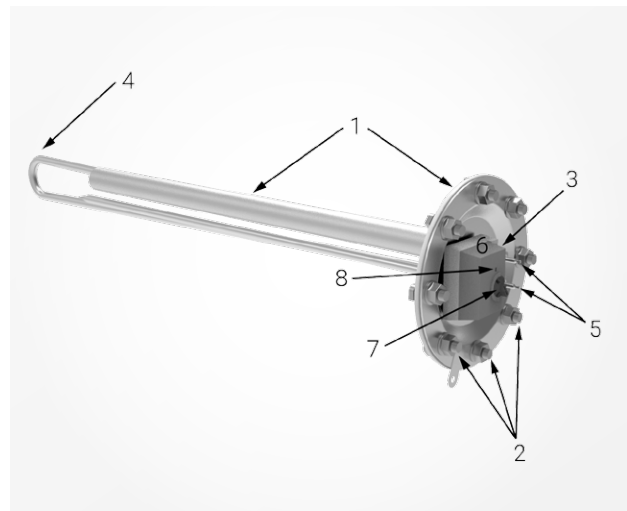

- [1] Flange of the heating unit and magnesium bar
- [2] Flange screws holes
- [3] Earthing terminal
- [4] Thermostat connection to the heating unit (factory setting)
- [5] Terminals
- [6] Thermostat
- [7] Temperature regulator
- [8] Overheating safety

CONNECTION OF THE ELECTRICAL HEATING UNIT TO THE THERMOSTAT

Switch off the main power switch. Remove the lid and check if the lugs of the terminals that connect the thermostat with the heating unit are properly tightened. Place the power supply cable and connect according to the electrical configuration diagram.

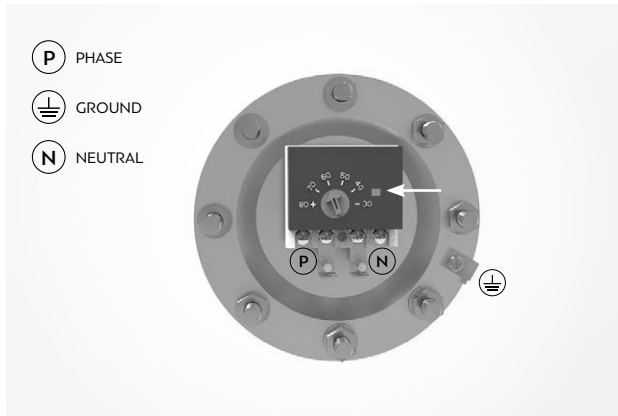

CAUTION!



CAUTION! THERE IS A SAFETY BUTTON ON THE THERMOSTAT. IF THE DEVICE'S TEMPERATURE EXCEEDS 110°C, THEN THE SAFETY BUTTON WILL BE ACTIVATED AND WILL BE DISLODGED. IN ORDER FOR THE HEATING UNIT TO OPERATE AGAIN, PRESS THE BUTTON AND RESTORE IT IN ITS FORMER POSITION.

3. CLOSED CIRCUIT FILLING

CAUTION!



Before the closed circuit starts filling with anti-freeze liquid, first fill up the tank with water and cover the collectors.



1. Switch on both exits of the closed circuit that are on the top of the tank. Fill half of the closed circuit

approximately. Then pour in the anti-freeze solution, which is included in the packaging, using a funnel. After that, reconnect the water inflow and fill up the closed circuit.

CAUTION!



The last phase of the filling must be performed with a controlled inflow, as the solution may be very hot, so as to avoid the danger of flooding the closed circuit (safety valve connection point 1.5 to 2 bar) and of sustaining burns.



2. When the closed circuit is completely filled, seal both the safety valve and the plug. It is highly recommended, in order to achieve the device's optimal operation and efficiency to install an expansion tank on the closed circuit too. The expansion tank will absorb excess pressure and restrain the liquids of the circuit. As a result, they will not be rejected from the heater because of vaporization.

3. Uncover the collectors and clean the glass.

4. Check for leakages and make sure that the collectors' and the boiler's connection pipes, as well as the hot and cold water pipe towards the heater and the

adaptor are properly insulated, in order to avoid thermal losses and be protected from frost.

5. Upon completing the installation, the device must remain switched off for a couple of hours (according to weather conditions and sunshine), so that the hot water is not consumed and the closed circuit gets activated.

CAUTION!



Only non-toxic propylene glycol can be used as a thermal carrier in solar water heaters. The heater should not operate solely on water, even in areas where there is no frost (due to lack of non-corroding protection). The same type of mixture must be used, when replenishing the heater. Follow the instructions that are included in the product's packaging

RECOMMENDED SYSTEM INSPECTIONS

ATTENTION!



BECAUSE SYSTEM MAINTENANCE AND CONTROL ARE DEPENDING FROM EVERY LOCAL CLIMATE DATA, WATER QUALITY AND THE OWNERS USAGE THE MAINTENANCE FREQUENCY IS PART OF THE AGREEMENT BETWEEN THE SYSTEM OWNER AND THE MAINTAINER INSTALLATION AND SYSTEM CONTROLS MUST ALWAYS BE PERFORMED BY AUTHORIZED SPECIALISTS. THE DATA OF MAINTENANCE SHOULD BE ALWAYS RECORDED IN THE MAINTENANCE BOOK FROM THE INSTALLER.

SYSTEM CHECK UPS

- Annually – preferably before the start of the high usage period to ensure that the heater operates properly and all the parts are in good working condition.
- Maintenance periods are determined upon delivery of the heater. During maintenance, you have to make sure that the following parts work properly:
 - Solar collectors
 - Solar circuit
 - Antifreeze liquid
 - Solar Tank
 - Fixation support
 - Safety valves

Before the winter months – You have to perform the following checks:

- Closed circuit liquids
- Insulation corrosions
- Leakages
- Safety valves
- SElectric element (if existing on the device)

During the summer months, provided that the hot water is not totally consumed and the temperature is high, part or the whole selective surface has to be covered.

In case of a long absence during the summer months, the collectors must be completely covered. That way, you will avoid replenishing the liquids in the closed circuit after the end of the summer. In addition, you increase the solar heater's life span, as you limit it's unreasonable strain during periods with high temperatures.

ATTENTION!



IN CASE THAT ALL THE NECESSARY MEASURES ARE NOT TAKEN AND THE SYSTEM IS OVERHEATED, EXCEEDING THE SAFETY TEMPERATURE OF 98 C, THEN THE SYSTEM IS OUT OF THE WARRANTY.

Devise maintenance

The solar water heater's maintenance must be performed according to the plan determined upon delivery. The maintenance book must always be completed after the maintenance man's visit.

Dismantling and Disposal

All the device's materials have to be properly disposed of, according to existing legislation. Uninstalling, transportation and other costs must be paid by the owner.

During of the constant evolution and improvement of the products and services, the manufacturer reserves the right to change or modify the information or of the specifications mentioned herein manual without prior notice or other obligation

